

SNMP

Simple Network Management Protocol

wangth

國立陽明交通大學資工系資訊中心

Computer Center of Department of Computer Science, NYCU

Network Management

- ❑ The network management is to
 - Monitor the network
 - Ensure the operations over the network are functional
 - Assure the network works efficiently
- ❑ An ounce of prevention is worth a pound of cure
 - Something wrong
 - Service down, fix the problem, resume the service
 - Nothing wrong
 - Service is somewhat abnormal, try to fix it online
- ❑ Requirements
 - FCAPS

Requirements of Network Management

❑ Fault Management

- Detect, isolate, reconfigure and repair the abnormal network environment
- Problem tracking and control

❑ Configuration Management

- Gather configuration information of network components

❑ Accounting Management

- Track the use of network resources by end-user to provide
 - Improprate usage tracing, charging, statistics

❑ Performance Management

- Capacity utilization, throughput, response time, bottleneck
 - Collect information and assess current situation

❑ Security Management

- Information protection and access control

In that time

- ❑ Network environment is simple
 - ICMP is the only way to do network investigation
 - ping, traceroute,
- ❑ As Internet goes popular, three approaches are proposed:
 - HEMS: High-level Entity Management System
 - Considered to be the first network management tools
 - SGMP and SNMP
 - SNMP was an enhanced version of the Simple Gateway Management Protocol
 - For TCP/IP-based network management standards
 - Supposed to be short-term solution
 - CMIP over TCP/IP (CMOT)
 - Common Management Information Protocol
 - For ISO-based network management standards
 - Supposed to be long-term solution

Introduction

□ SNMP – Simple Network Management Protocol

- A set of standards for network management
 - Protocol
 - Database structure specification
 - Data objects
- A set of standardized tools that
 - Control costs of network management
 - Across various product types
 - End system, bridges, routers, telecommunications, ...
- Two roles
 - Network management station: SNMP collector, manager
 - SNMP agent

History

- ❑ In 1989
 - SNMP was adopted as TCP/IP-based Internet standards
- ❑ In 1991
 - RMON – Remote network MONitoring
 - Supplement to SNMP to include management of LAN and WAN packet flow
- ❑ In 1995
 - SNMPv2 (2c)
 - Functional enhancements to SNMP
 - SNMP on OSI-based networks
 - RMON2
 - Network layer and application layer
- ❑ In 1998
 - SNMPv3
 - Precise definition, but the content is the same as SNMPv2
 - Security capability for SNMP

The roles in SNMPv3

SNMP Entity

SNMP Engine

Dispatcher

Message
Processing
Subsystem

Security
Subsystem

Access
Control
Subsystem

Application(s)

Dispatcher
Generator

Notification
Receiver(M)

Proxy
Forwarder(A)

Command
Responder(A)

Notification
Originator(M,A)

Other(A)

Network Management System (1)

- ❑ A collection of tools for
 - Network monitoring
 - Network control

- ❑ These tools must be integrated
 - Single operator interface with powerful but user-friendly
 - Support of managed equipment

Network Management System (2)

□ Architecture of NMS

- NMA
 - Operator interface
- NME
 - Collect statistics
 - Response to NMA
 - Alert NMA when environment changing

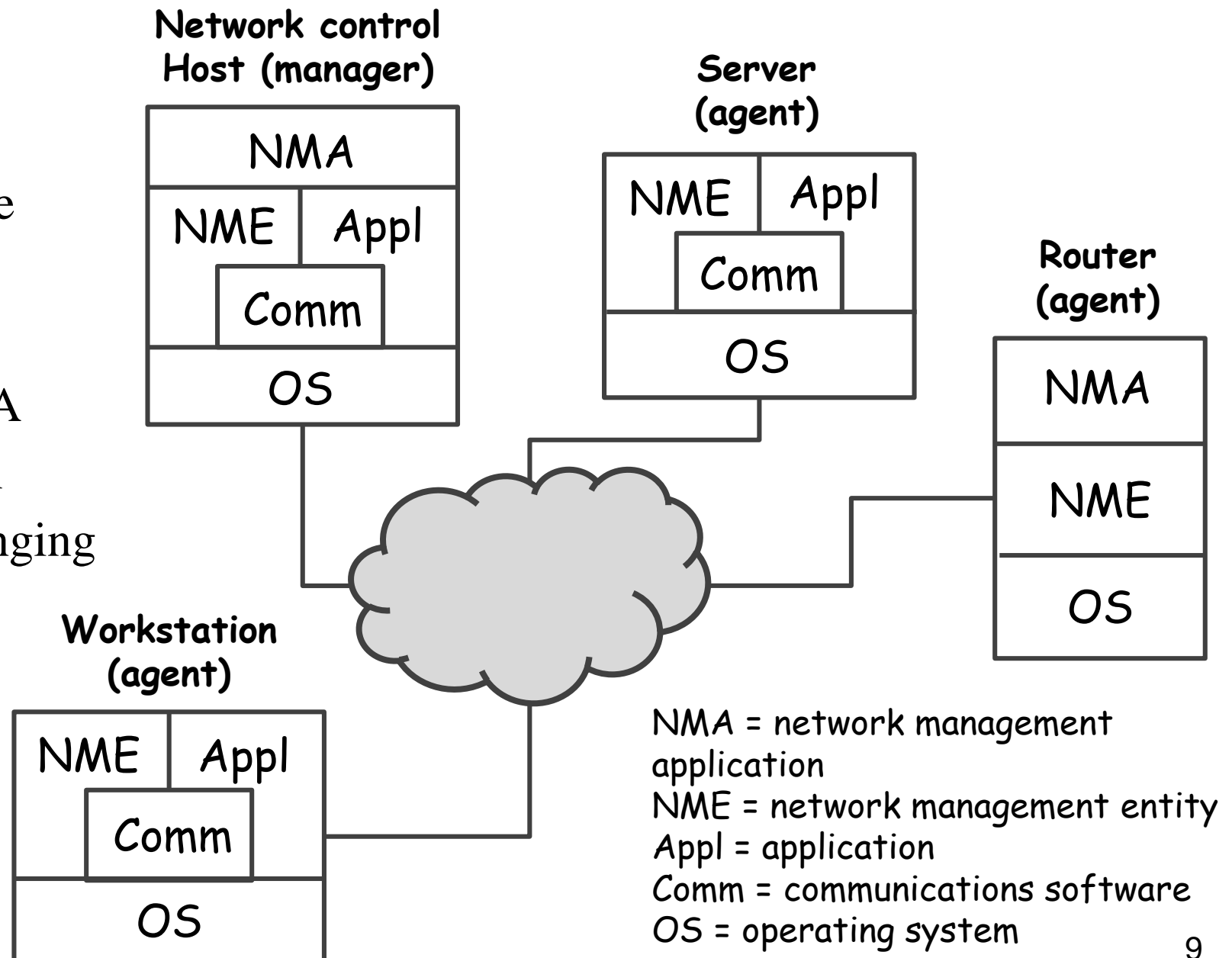

SNMP Concepts

國立陽明交通大學資工系資訊中心

Computer Center of Department of Computer Science, NYCU

SNMP Architecture (2)

□ SNMP

- UDP
- Port 161(snmp)
- Port 162(snmp-trap)

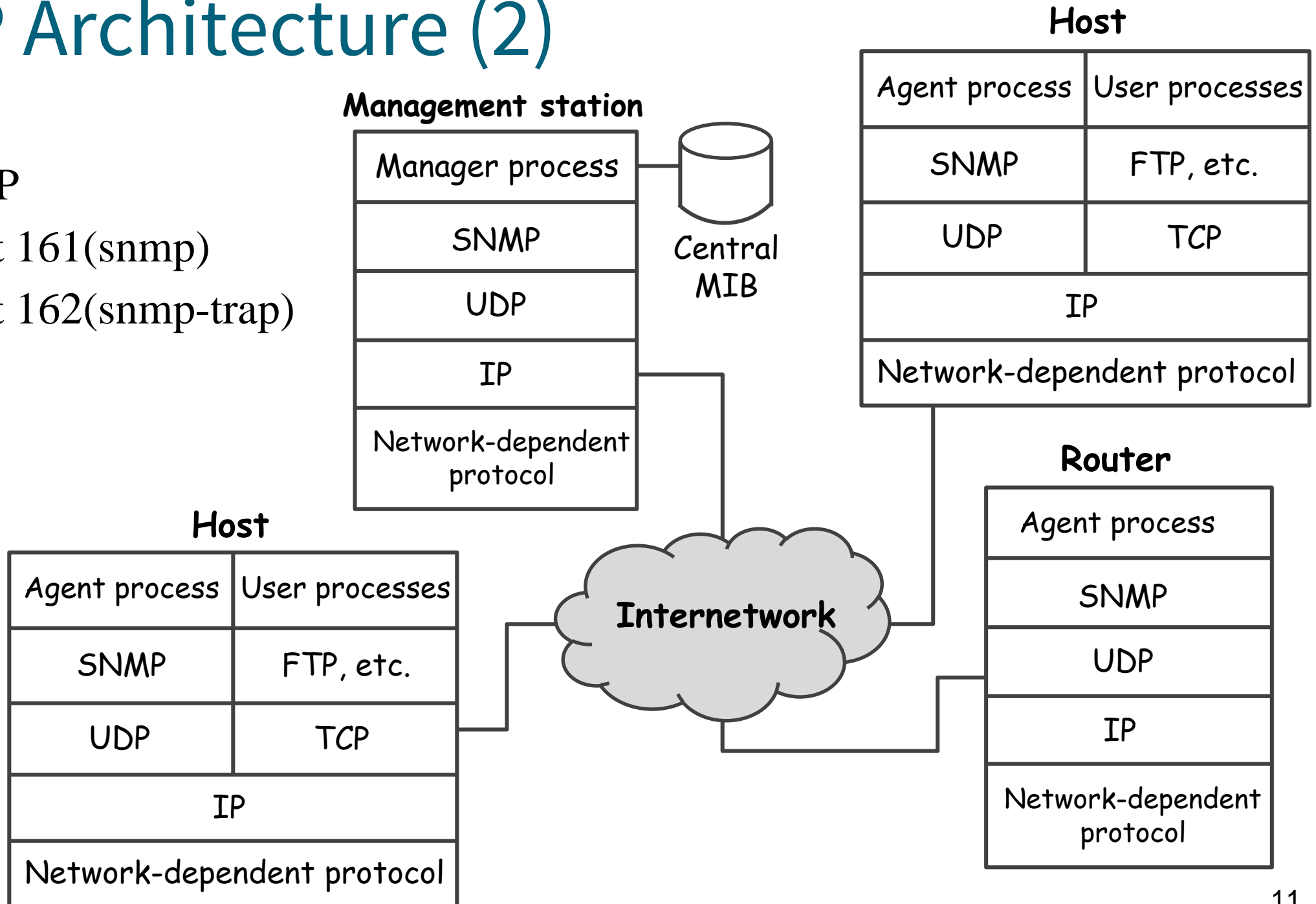

SNMP Architecture (3)

□ SNMP proxy

- Devices that do not support UDP/IP
 - e.g., Bridge, Modem
- Devices that do not want to add burden of SNMP agent
 - e.g., PC, programmable controller

Management station

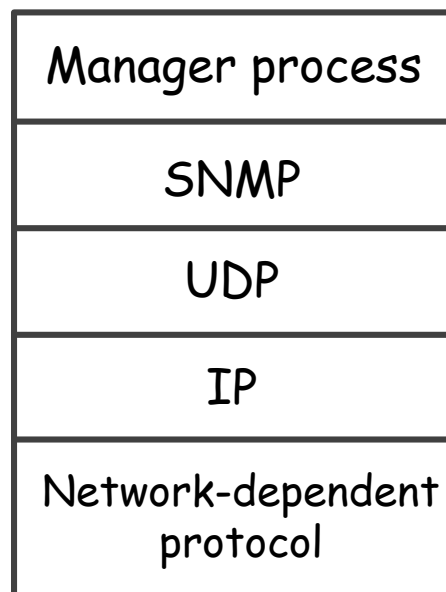

Proxy agent

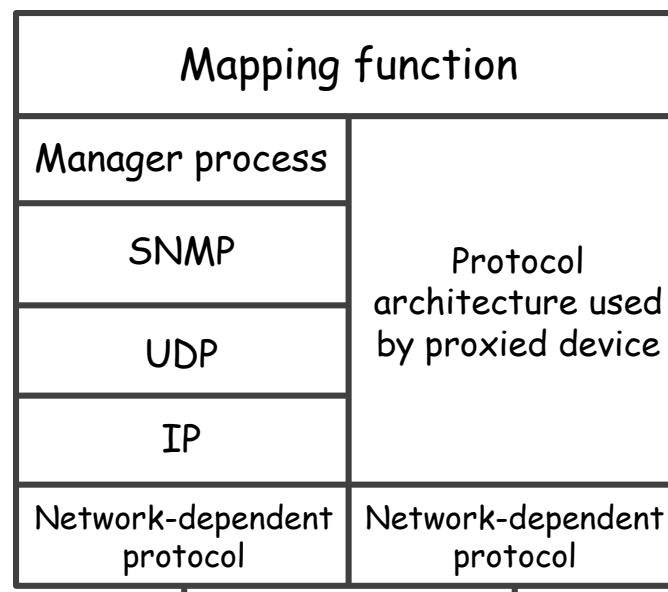

Proxied device

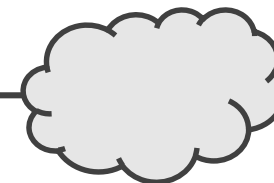
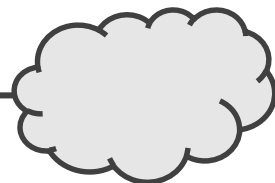
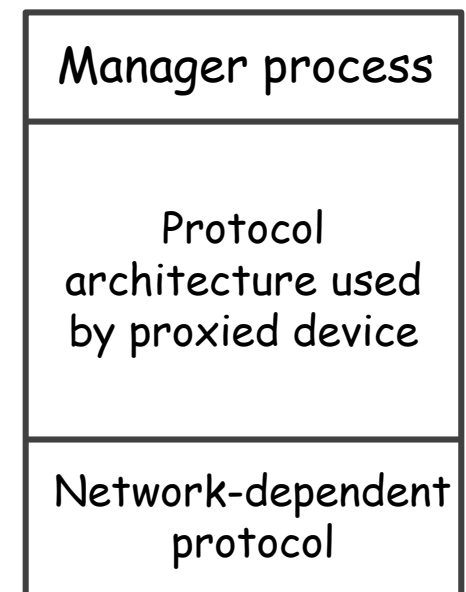

SNMP Management Information

- ❑ Management Information Base (MIB)
 - Collection of objects
 - Each object represents certain resource of managed device
- ❑ Interoperability of MIB
 - Object that represents a particular resource should be the same cross various system
 - What objects
 - (MIB-I) and MIB-II
 - Common representation format
 - SMI (Structure of Management Information)

SNMP Management Information – SMI (1)

□ SMI

- Structure of Management Information
- Identify the data type that can be used in MIB
- How resources are represented and named, including
 - MIB structure
 - Syntax and value of each object
 - Encoding of object value

SNMP Management Information – SMI (2)

□ MIB structure

- Rooted tree
 - The leaves are the actual managed objects
 - Each object has an identifier (OBJECT IDENTIFIER)
 - Number with dot as delimiter
 - The internet node
 - iso(1) -> org(3) -> dod(6) -> internet(1)
 - object identifier of internet node: 1.3.6.1
 - Under internet node
 - directory(1) :OSI X.500 directory
 - **mgmt(2): used for objects defined in IAB (Internet Activities Board)**
 - experimental(3): used for internet experiments
 - private(4): unilaterally usage

SNMP Management Information – SMI (3)

- MIB Tree
- Define additional objects
 - Under mib-2
 - 1.3.6.1.2.1
 - Under experimental
 - 1.3.6.1.3
 - Under enterprises
 - 1.3.6.1.4.1

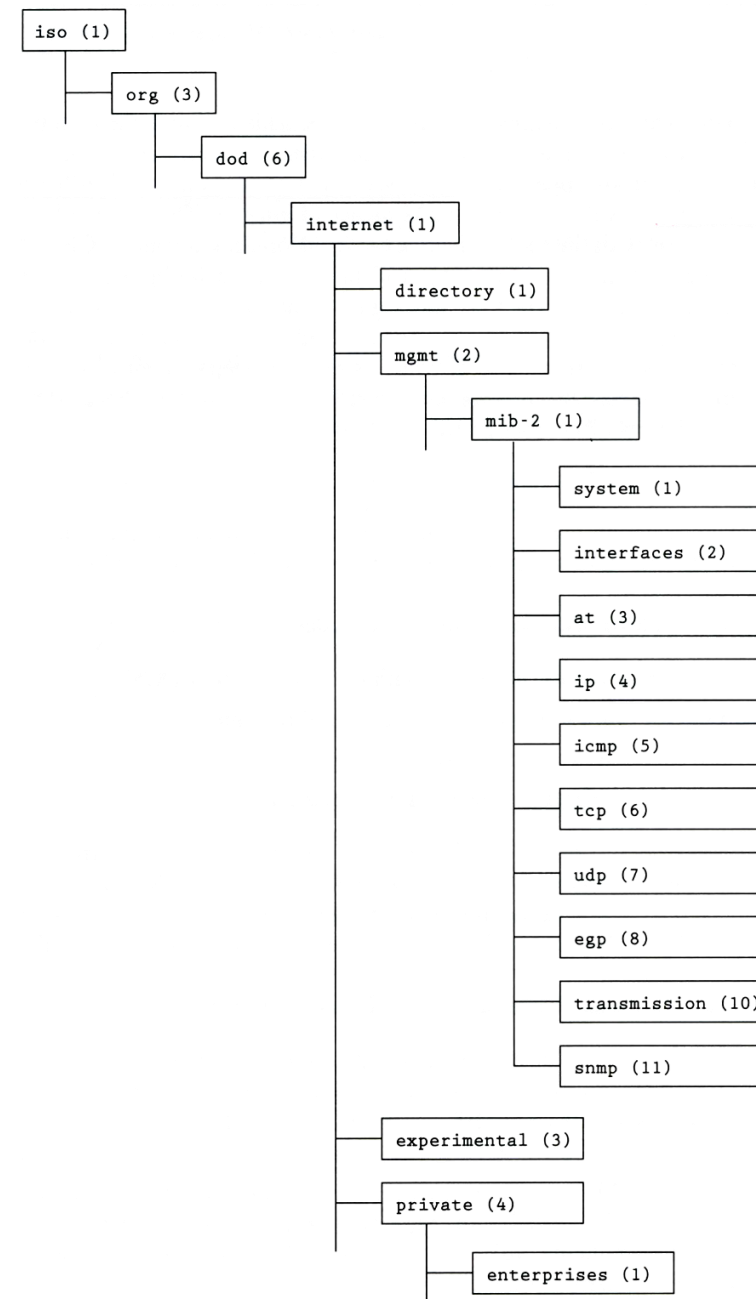

SNMP Management Information – Object Syntax (1)

□ Definition of object

- Data type
 - Application-independent type (UNIVERSAL type)
 - Integer, Octet String, Object Identifier, Null, Sequence, Sequence Of
 - Application-wide types (RFC 1155)
 - NetworkAddress Not used
 - IpAddress
 - Counter (0 ~ 2³² -1), increasing only, wrap to 0
 - Gauge (0 ~ 2³² -1)
 - TimeTicks
 - Opaque (encoded as OCTET STRING for transmission)
- Value ranges
- Relationship with other objects in MIB

SNMP Management Information – Object Syntax (2)

□ ASN.1

- Abstract Syntax Notation One
- A formal language developed by CCITT and ISO
- In SNMP, we use macro to define other types used to define managed objects
 - Macro definition (template)
 - Macro instance (particular type)
 - Macro instance value

SNMP Management Information – Object Syntax (3)

❑ Example: /usr/share/snmp/mibs/BEGEMOT-HOSTRES-MIB.txt

```
-- Additional stuff for the HOST-RESOURCES MIB.
BEGEMOT-HOSTRES-MIB DEFINITIONS ::= BEGIN

IMPORTS
    MODULE-IDENTITY, OBJECT-TYPE, TimeTicks
        FROM SNMPv2-SMI
    begemot
        FROM BEGEMOT-MIB;

begemotHostres MODULE-IDENTITY
    ...
    ::= { begemot 202 }

begemotHostresObjects OBJECT IDENTIFIER ::= { begemotHostres 1 }

begemotHrStorageUpdate OBJECT-TYPE
    SYNTAX      TimeTicks
    MAX-ACCESS  read-write
    STATUS      current
    DESCRIPTION
        "The maximum number of ticks the storage table is cached."
    ::= { begemotHostresObjects 1 }
```

SNMP Management Information – Object Syntax (4)

□ OBJECT-Type macro

```
IMPORTS   ObjectName, Object Syntax FROM RFC-1155-SMI

OBJECT-TYPE MACRO ::=
BEGIN
    TYPE NOTATION ::=   "SYNTAX"   type (TYPE ObjectSyntax)
                       "ACCESS"   Access
                       "STATUS"   Status
                               DescrPart
                               ReferPart
                               IndexPart
                               DefValPart
    VALUE NOTATION ::= value (VALUE ObjectName)

    Access ::= "read-only"|"read-write"|"write-only"|"not-accessible"

    Status ::= "mandatory"|"optional"|"obsolete"|"deprecated"

    DescrPart ::= "DESCRIPTION" value (description DisplayString)|empty

    ReferPart ::= "REFERENCE" value (reference DisplayString)|empty

    IndexPart ::= "INDEX" "{" IndexTypes "}"

    IndexTypes ::= IndexType|IndexTypes "," IndexType

    IndexType ::= value (indexobject ObjectName) --if indexobject, use the SYNTAX
                                                    --value of the correspondent
                                                    --OBJECT-TYPE invocation
                                                    |type (indextype) --otherwise use named SMI type;
                                                    --must conform to IndexSyntax below

    DefValPart ::= "DEFVAL" "{" value (defvalue ObjectSyntax) "}" |empty

    DisplayString ::= OCTET STRING SIZE (0..255)

END

IndexSyntax ::= CHOICE { number INTEGER (0..MAX),
                          string OCTET STRING,
                          object OBJECT IDENTIFIER,
                          address NetworkAddress,
                          IpAddress IpAddress }
```

SNMP Management Information – Object Syntax (5)

□ Example of object definition

- iso.org.dod.internet.mgmt.mib-2.tcp.tcpMaxConn
- 1.3.6.1.2.1.6.4

```
tcpMaxConn OBJECT-TYPE  
    SYNTAX INTEGER  
    ACCESS read-only  
    STATUS mandatory  
    DESCRIPTION
```

```
        "The limit on the total number of TCP connections the entity can  
        support. In entities where the maximum number of connections is  
        dynamic, this object should contain the value -1."
```

```
 ::= { tcp 4 }
```

SNMP Management Information – Object Syntax (6)

□ 2-D table

- Two-dimensional array with scalar-valued entries
- Ex: tcpConnTable (RFC1213)

```
tcpConn Table OBJECT-TYPE
    SYNTAX      SEQUENCE OF TcpConnEntry
    ACCESS      not-accessible
    STATUS      mandatory
    DESCRIPTION
        "A table containing TCP connection-specific information."
    ::= { tcp 13 }
```

```
tcpConnEntry OBJECT-TYPE
    SYNTAX      TcpConnEntry
    ACCESS      not-accessible
    STATUS      mandatory
    DESCRIPTION
        "Information about a particular TCP connection. An object of this type is
        transient, in that it ceases to exist when (or soon after) the connection
        makes the transition to the CLOSED state."
    INDEX       { tcpConnLocalAddress,
                 tcpConnLocalPort,
                 tcpConnRemAddress,
                 tcpConnRemPort }
    ::= { tcpConnTable 1 }
```

```
TcpConnEntry ::= SEQUENCE {
    tcpConnState INTEGER,
    tcpConnLocalAddress IpAddress,
    tcpConnLocalPort INTEGER (0..65535),
    tcpConnRemAddress IpAddress,
    tcpConnRemPort INTEGER (0..65535)}
```

SNMP Management Information – Object Syntax (7)

```
tcpConnState OBJECT-TYPE
    SYNTAX  INTEGER {closed (1),
                    listen (2),
                    synSent (3),
                    synReceived (4),
                    established (5),
                    finWait1 (6),
                    finWait2 (7),
                    closeWait (8),
                    lastAck (9),
                    closing (10),
                    timeWait (11),
                    delete TCB (12) }

    ACCESS      read-write
    STATUS      mandatory
    DESCRIPTION
        "The state of this TCP connection."
```

```
 ::= { tcpConnEntry 1 }

tcpConnLocalAddress OBJECT-TYPE
    SYNTAX      IPAddress
    ACCESS      read-only
    STATUS      mandatory
    DESCRIPTION
        "The local IP address for this TCP connection. In the case of a connection in the listen state which is willing to accept connections for any IP interface associated with the node, the value 0.0.0.0 is used."
    ::= { tcpConnEntry 2 }

tcpConnLocalPort OBJECT-TYPE
    SYNTAX      INTEGER (0..65535)
    ACCESS      read-only
    STATUS      mandatory
    DESCRIPTION
        "The local port number for this TCP connection."
    ::= { tcpConnEntry 3 }

tcpConnRemAddress OBJECT-TYPE
    SYNTAX      IPAddress
    ACCESS      read-only
    STATUS      mandatory
    DESCRIPTION
        "The remote IP address for this TCP connection."
    ::= { tcpConnEntry 4 }

tcpConnRemPort OBJECT-TYPE
    SYNTAX      INTEGER (0..65535)
    ACCESS      read-only
    STATUS      mandatory
    DESCRIPTION
        "The remote port number for this TCP connection."
    ::= { tcpConnEntry 5 }
```

SNMP Management Information – Object Syntax (8)

- iso (1) -> org (3) -> dod (6) -> internet (1) -> mgmt (2)
 - mib-2 (1) -> tcp (6) -> tcpConnTable(13)

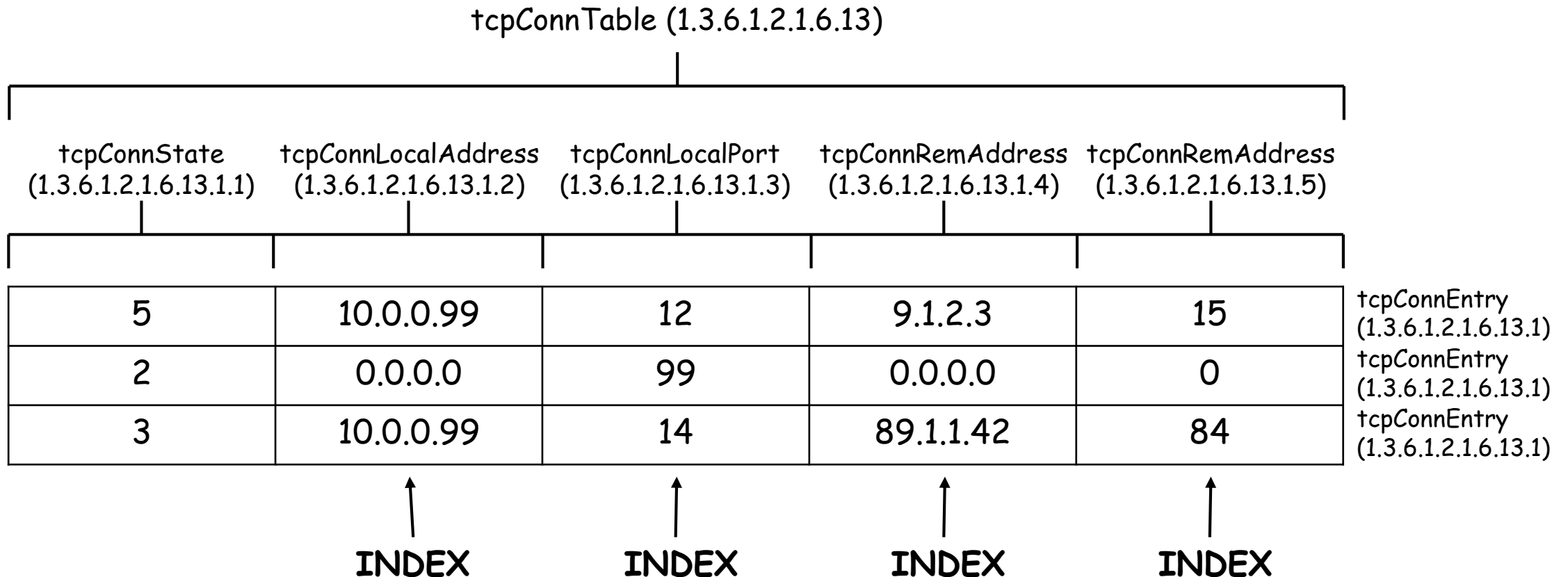

Standard MIBs

國立陽明交通大學資工系資訊中心

Computer Center of Department of Computer Science, NYCU

MIB-II (1)

□ RFC1213

- MIB-I (RFC 1156)
- MIB-II is a superset of MIB-I with some additional objects and groups

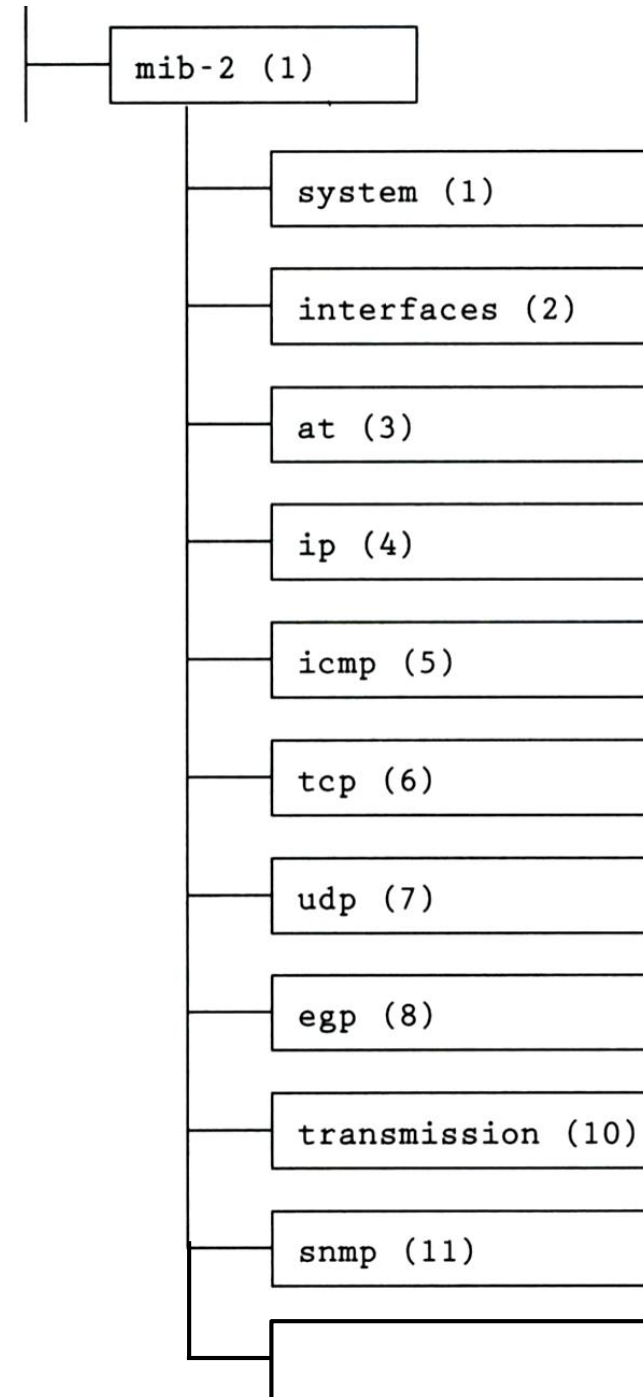

MIB-II (2)

□ First layer under mib-2

- 1.3.6.1.2.1 (iso.org.dod.internet.mgmt.mib-2)
- system
 - Overall information about the system
- interfaces
 - Information about each interface
- at
 - Address translation (obsolete)
- ip, icmp, tcp, udp, egp
- transmission
 - Transmission schemes and access protocol at each system interface
- snmp

MIB-II system group

□ sysServices

- 1 physical (ex: repeater)
- 2 datalink/subnetwork (ex: bridge)
- 3 internet (ex: router)
- 4 end-to-end (ex: IP hosts)
- 7 applications (ex: mail relays)

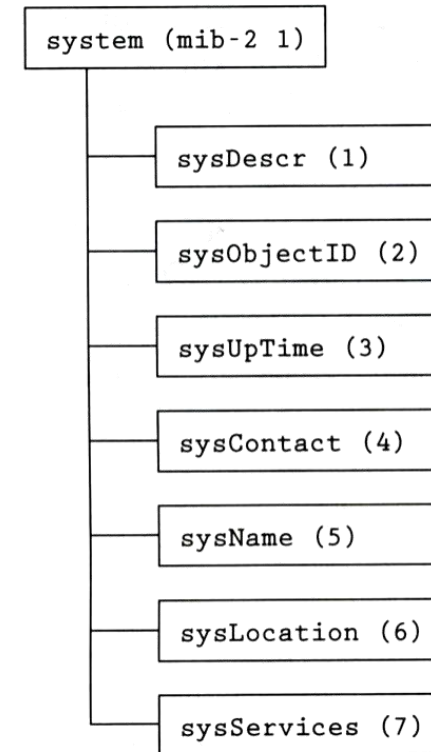

Object	Syntax	Access	Description
sysDescr	DisplayString (SIZE(0...255))	RO	A description of the entity, such as hardware, operating system, etc.
sysObjectID	OBJECT IDENTIFIER	RO	The vendor's authoritative identification of the network management subsystem contained in the
sysUpTime	TimeTicks	RO	The time since the network management portion of the system was last reinitialized
sysContact	DisplayString (SIZE(0...255))	RW	The identification and contact information of the contact person for this managed node
sysName	DisplayString (SIZE(0...255))	RW	An administratively assigned name for this managed node
sysLocation	DisplayString (SIZE(0...255))	RW	The physical location of this node
sysServices	INTEGER (0...127)	RO	A value that indicates the set of services this entity primarily offers

MIB-II interface group (1)

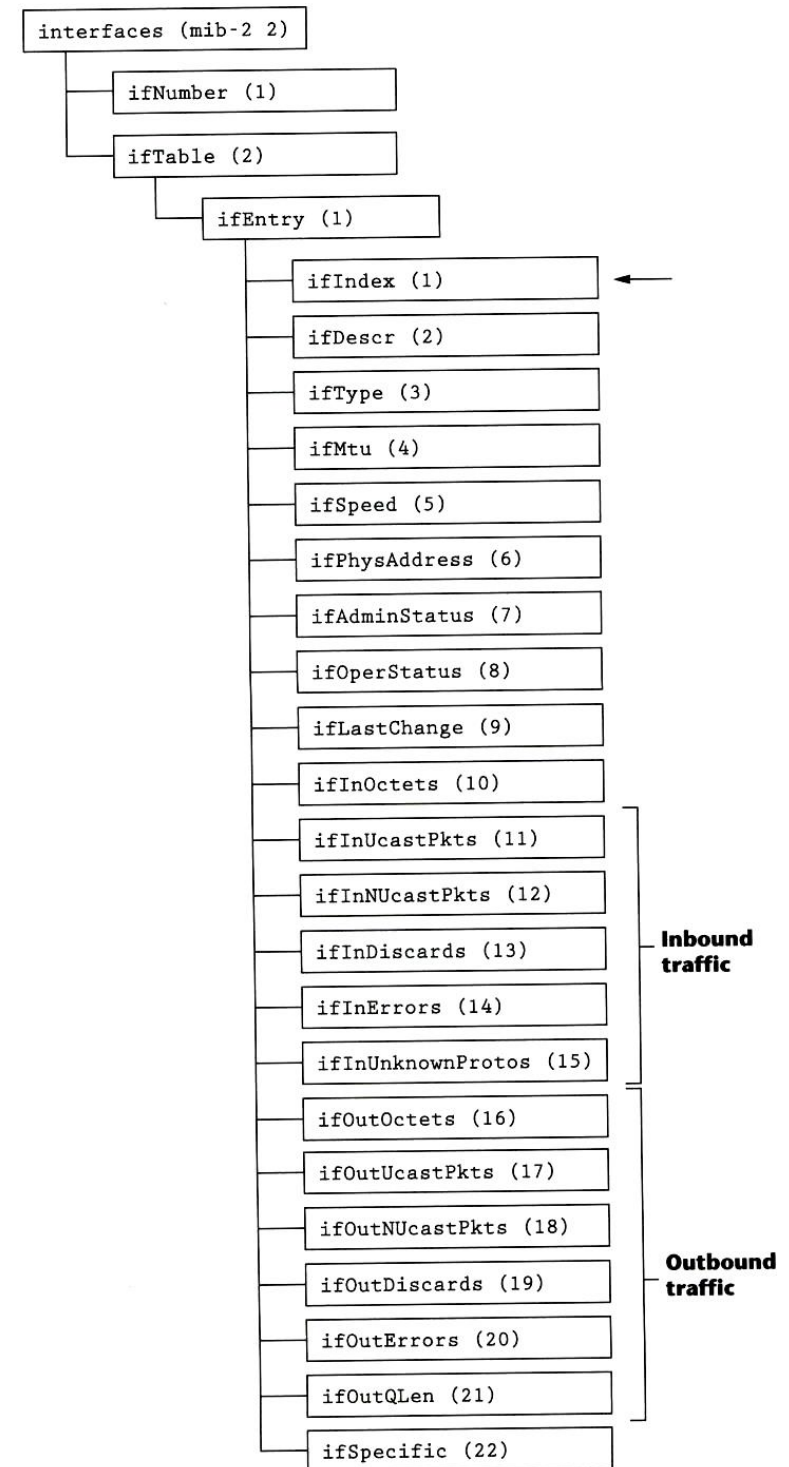

MIB-II interface group (2)

TABLE 6.2 interfaces Group Objects

Object	Syntax	Access	Description
ifNumber	INTEGER	RO	The number of network interfaces
ifTable	SEQUENCE OF ifEntry	NA	A list of interface entries
ifEntry	SEQUENCE	NA	An interface entry containing objects at the subnetwork layer and below for a particular interface
ifIndex	INTEGER	RO	A unique value for each interface
ifDescr	DisplayString (SIZE (0 ... 255))	RO	Information about the interface, including name of manufacturer, product name, and version of the hardware interface
ifType	INTEGER	RO	Type of interface, distinguished according to the physical/link protocol(s)
ifMtu	INTEGER	RO	The size of the largest protocol data unit, in octets, that can be sent/received on the interface
ifSpeed	Gauge	RO	An estimate of the interface's current data rate capacity
ifPhysAddress	PhysAddress	RO	The interface's address at the protocol layer immediately below the network layer
ifAdminStatus	INTEGER	RW	Desired interface state (up(1), down(2), testing(3))
ifOperStatus	INTEGER	RO	Current operational interface state (up(1), down(2), testing(3))
ifLastChange	TimeTicks	RO	Value of sysUpTime at the time the interface entered its current operational state
ifInOctets	Counter	RO	Total number of octets received on the interface, including framing characters
ifInUcastPkts	Counter	RO	Number of subnetwork-unicast packets delivered to a higher-layer protocol
ifInNUcastPkts	Counter	RO	Number of nonunicast packets delivered to a higher-layer protocol
ifInDiscards	Counter	RO	Number of inbound packets discarded, even though no errors had been detected, to prevent their being deliverable to a higher-layer protocol (e.g., buffer overflow)
ifInErrors	Counter	RO	Number of inbound packets that contained errors preventing them from being deliverable to a higher-layer protocol
ifInUnknownProtos	Counter	RO	Number of inbound packets that were discarded because of an unknown or unsupported protocol
ifOutOctets	Counter	RO	Total number of octets transmitted on the interface, including framing characters
ifOutUcastPkts	Counter	RO	Total number of packets that higher-level protocols requested be transmitted to a sub-network-unicast address, including those that were discarded or otherwise not sent
ifOutNUcastPkts	Counter	RO	Total number of packets that higher-level protocols requested be transmitted to a nonunicast address, including those that were discarded or otherwise not sent
ifOutDiscards	Counter	RO	Number of outbound packets discarded even though no errors had been detected to prevent their being transmitted (e.g., buffer overflow)
ifOutErrors	Counter	RO	Number of outbound packets that could not be transmitted because of errors
ifOutQLen	Gauge	RO	Length of the output packet queue
ifSpecific	OBJECT IDENTIFIER	RO	Reference to MIB definitions specific to the particular media being used to realize the interface

MIB-II tcp group

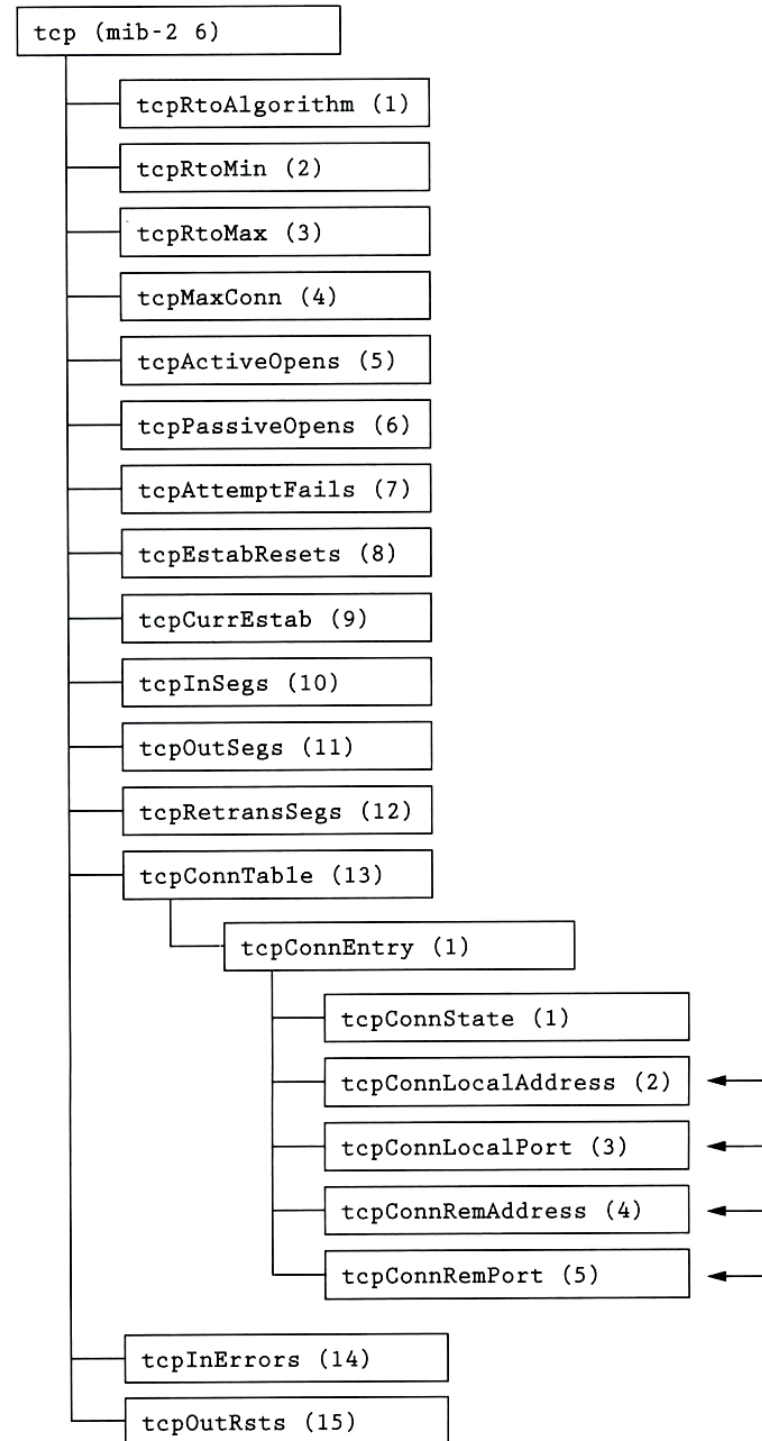

MIB-II ip group

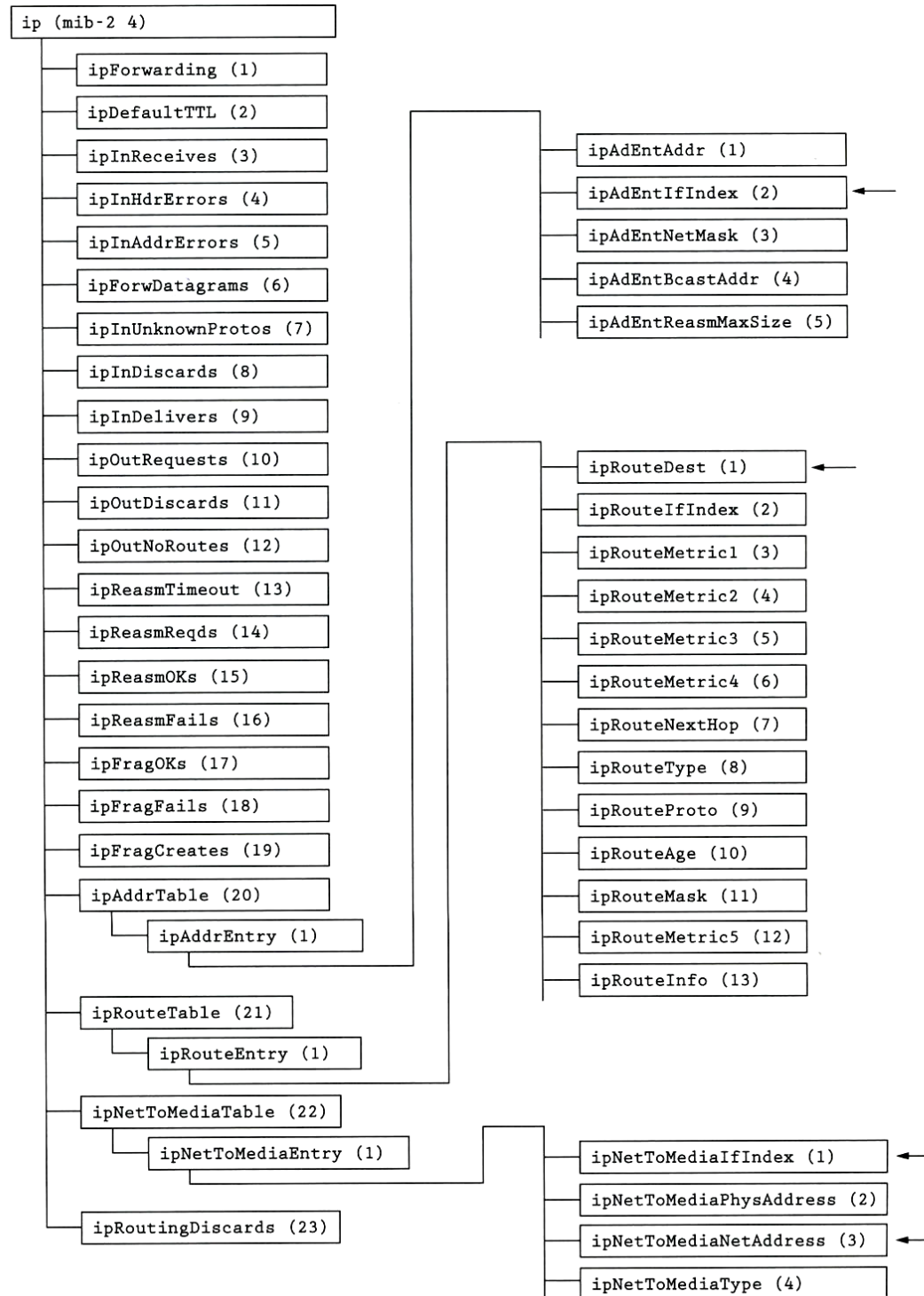

Host Resources MIB

□ RFC2790

- host OBJECT IDENTIFIER ::= { mib-2 25 }
- hrSystem OBJECT IDENTIFIER ::= { host 1 }
- hrStorage OBJECT IDENTIFIER ::= { host 2 }
- hrDevice OBJECT IDENTIFIER ::= { host 3 }
- hrSWRun OBJECT IDENTIFIER ::= { host 4 }
- hrSWRunPerf OBJECT IDENTIFIER ::= { host 5 }
- hrSWInstalled OBJECT IDENTIFIER ::= { host 6 }
- hrMIBAdminInfo OBJECT IDENTIFIER ::= { host 7 }

SNMP Protocol

國立陽明交通大學資工系資訊中心

Computer Center of Department of Computer Science, NYCU

SNMP Protocol

❑ Supported operations

- get, getnext, set, getresponse, trap, ...

❑ Simplicity vs. limitations

- Not possible to change the structure of MIB by adding or deleting object instances
- Access is provided only to leaf objects

SNMP Protocol – security concern

□ In management environment

- The management station and managed agent
 - One-to-many relationship
 - One station may manage all or a subset of target
- The managed agent and management station
 - One-to-many relationship
 - Each managed agent controls its local MIB and must be able to control the use of that MIB
 - Three aspects
 - Authentication service
 - Access policy
 - Proxy service

SNMP Protocol – communities (1)

□ An SNMP community

- A relationship between an SNMP agent and a set of SNMP managers that defines
 - Authentication, access control and proxy
- The managed system establishes one community for each combination of authentication, access control and proxy
- Each community has a unique “community name”
- Management station use certain community name in all get and set operations

SNMP Protocol – communities (2)

❑ Authentication

- The community name (password)

❑ Access policy

- Community profile
 - SNMP MIB view
 - A subset of MIB objects
 - SNMP access mode
 - read-only, read-write, write-only, non-accessible

SNMP Protocol – Where is the security

□ SNMPv3

- User-based Security Model (USM)
 - Message Authentication
 - HMAC
 - ✓ MD5, SHA-1
 - ✓ Authentication passphrase, secret key
 - Encryption
 - CBC-DES
- View-based Access Control Model (VACM)
 - Context table
 - Security to group table
 - Access table
 - View tree family table

BSNMP

mini SNMP daemon

國立陽明交通大學資工系資訊中心

Computer Center of Department of Computer Science, NYCU

BSNMP (1)

- ❑ A portable SNMP framework consisting of a daemon (bsnmpd), modules and tools
 - ❑ Enable bsnmpd
 - /etc/rc.conf
- ```
bsnmpd_enable="YES"
```
- ❑ Configure bsnmpd
    - /etc/snmpd.config
  - ❑ Start bsnmpd
    - /etc/rc.d/bsnmpd start
    - Firewall allows
      - snmpd: udp 161
      - snmptrapd: udp 162

```
location := "Room 200"
contact := "sysmeister@example.com"
system := 1 # FreeBSD
traphost := localhost
trapport := 162

Change this!
read := "public"

Host resources module
This requires the mibII module.
#
#begemotSnmpdModulePath."hostres" =
"/usr/lib/snmp_hostres.so"
```

# BSNMP (2)

## ❑ bsnmp-ucd

- bsnmpd module that implements parts of UCD-SNMP-MIB
- The counters will be available under the following MIB: .1.3.6.1.4.1.2021 (UCD-SNMP-MIB::ucdavis)

## ❑ Install bsnmp-ucd

- net-mgmt/bsnmp-ucd

## ❑ Configure bsnmpd

- /etc/snmpd.config

```
begemotSnmpdModulePath."ucd" = "/usr/local/lib/snmp_ucd.so"
```

## ❑ Restart bsnmpd

## ❑ Other bsnmp modules

- bsnmp-jails
- bsnmpd module to measure statistics about jails
- bsnmp-regex
- bsnmpd module allowing creation of counters from log files

# Net-SNMP

previously known as "ucd-snmp"

國立陽明交通大學資工系資訊中心

Computer Center of Department of Computer Science, NYCU

# Net-SNMP (1)

## □ Install net-snmp

- net-mgmt/net-snmp
- # make [OPTIONS] install clean

```
DEFAULT_SNMP_VERSION="3" Default version of SNMP to use.
NET_SNMP_SYS_CONTACT="nobody@nowhere.invalid"
 Default system contact.
NET_SNMP_SYS_LOCATION="somewhere"
 Default system location.
NET_SNMP_LOGFILE="/var/log/snmpd.log"
 Default log file location for snmpd.
NET_SNMP_PERSISTENTDIR="/var/net-snmp"
 Default directory for persistent data storage.
```

- Firewall allows
  - snmpd: udp 161
  - snmptrapd: udp 162

# Net-SNMP (1)

## □ After installing...

If you want to auto-start snmpd and snmptrapd:, add the following to /etc/rc.conf:

```
snmpd_enable="YES"
snmpd_flags="-a"
snmpd_confdir="/usr/local/share/snmp/snmpd.conf /etc/snmpd.conf"
snmptrapd_enable="YES"
snmptrapd_flags="-a -p /var/run/snmptrapd.pid"
```

- /usr/local/share/snmp/snmpd.conf.example

```
 # Full access from the local host
rocommunity public localhost
 # Default access to basic system info
rocommunity public default -V systemonly
```

# Net-SNMP (3)

## □ Use snmpconf command to generate the configuration files

- snmpconf -g basic\_setup
- snmpconf
  - System Information Setup
    - Location, contact, service
  - Access Control Setup
    - SNMPv3 or SNMPv1 access community
  - Trap Destination
    - Where to send the trap
  - Monitor Various Aspects of the Running Host
    - Process, disk space, load, file
  - Extending the Agent
    - Let snmp agent to return information that yourself define
  - Agent Operating Mode
    - User/group, IP port,...

# Net-SNMP (4)

## □ To get various value

- man snmpget, snmpgetnext, snmptable

```
% snmpget -c public -v 1 nasa system.sysContact.0
```

```
% snmpgetnext -c public -v 1 nasa system.sysContact.0
```

```
% snmptable -c public -v 1 nasa mib-2.tcp.tcpConnTable
```

```
% snmpwalk -c public -v 1 nasa system
```

```
% snmpwalk -c public -v 1 nasa iso.org.dod.internet.private.enterprises
```

# Appendix

## Cacti

國立陽明交通大學資工系資訊中心

Computer Center of Department of Computer Science, NYCU



# Cacti(1)

## □ About

- Cacti is a complete network graphing solution designed to harness the power of **RRDTool's** data storage and graphing functionality.
- Cacti provides a fast poller, advanced graph templating, multiple data acquisition methods, and user management features out of the box.
- All of this is wrapped in an intuitive, easy to use interface that makes sense for LAN-sized installations up to complex networks with hundreds of devices.

## □ Install cacti

- `/usr/ports/net/cacti`

# Cacti(2)

## Cacti Installation Guide

Thanks for taking the time to download and install cacti, the complete graphing solution for your network. Before you can start making cool graphs, there are a few pieces of data that cacti needs to know.

Make sure you have read and followed the required steps needed to install cacti before continuing. Install information can be found for [Unix](#) and [Win32](#)-based operating systems.

Also, if this is an upgrade, be sure to reading the [Upgrade](#) information file.

Cacti is licensed under the GNU General Public License, you must agree to its provisions before continuing:

This program is free software; you can redistribute it and/or modify it under the terms of the GNU General Public License as published by the Free Software Foundation; either version 2 of the License, or (at your option) any later version.

This program is distributed in the hope that it will be useful, but WITHOUT ANY WARRANTY; without even the implied warranty of MERCHANTABILITY or FITNESS FOR A PARTICULAR PURPOSE. See the GNU General Public License for more details.

[Next >>](#)

# Cacti(3)

## Cacti Installation Guide

Please select the type of installation

New Install

The following information has been determined from Cacti's configuration file. If it is not correct, please edit 'include/config.php' before continuing.

```
Database User: cactiuser
Database Hostname: localhost
Database: cacti
Server Operating System Type: unix
```

Next >>

# Cacti(4)

### Cacti Installation Guide

Make sure all of these values are correct before continuing.

**[NOT FOUND] RRDTool Binary Path:** The path to the rrdtool binary.  
  
**[ERROR: FILE NOT FOUND]**

**[FOUND] PHP Binary Path:** The path to your PHP binary file (may require a php recompile to get this file).  
  
**[OK: FILE FOUND]**

**[NOT FOUND] snmpwalk Binary Path:** The path to your snmpwalk binary.  
  
**[ERROR: FILE NOT FOUND]**

**[NOT FOUND] snmpget Binary Path:** The path to your snmpget binary.  
  
**[ERROR: FILE NOT FOUND]**

**[NOT FOUND] snmpbulkwalk Binary Path:** The path to your snmpbulkwalk binary.  
  
**[ERROR: FILE NOT FOUND]**

**[NOT FOUND] snmpgetnext Binary Path:** The path to your snmpgetnext binary.  
  
**[ERROR: FILE NOT FOUND]**

**[FOUND] Cacti Log File Path:** The path to your Cacti log file.  
  
**[OK: FILE FOUND]**

**SNMP Utility Version:** The type of SNMP you have installed. Required if you are using SNMP v2c or don't have embedded SNMP support in PHP.

**NOTE:** Once you click "Finish", all of your settings will be saved and your database will be upgraded if this is an upgrade. You can change any of the settings on this screen at a later time by going to "Cacti Settings" from within Cacti.

**Finish**

# Cacti(5)

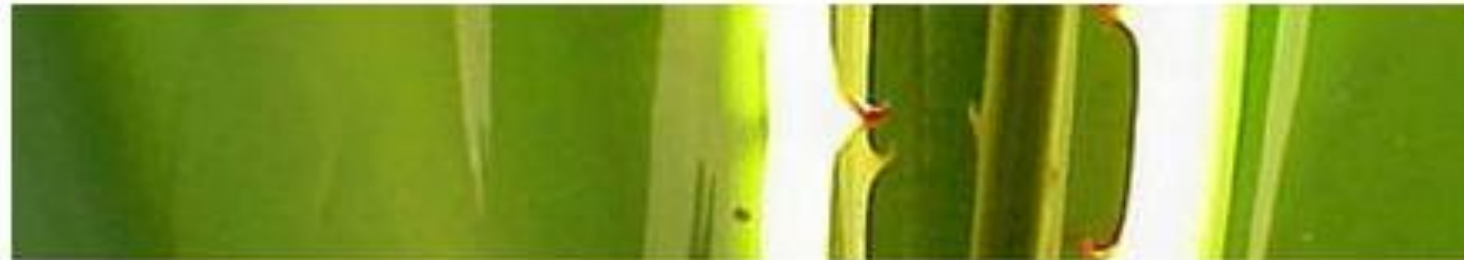

## User Login

Please enter your Cacti user name and password below:

User Name:

Password:

- ❑ Default account/pwd
  - admin/admin

# Cacti(6)

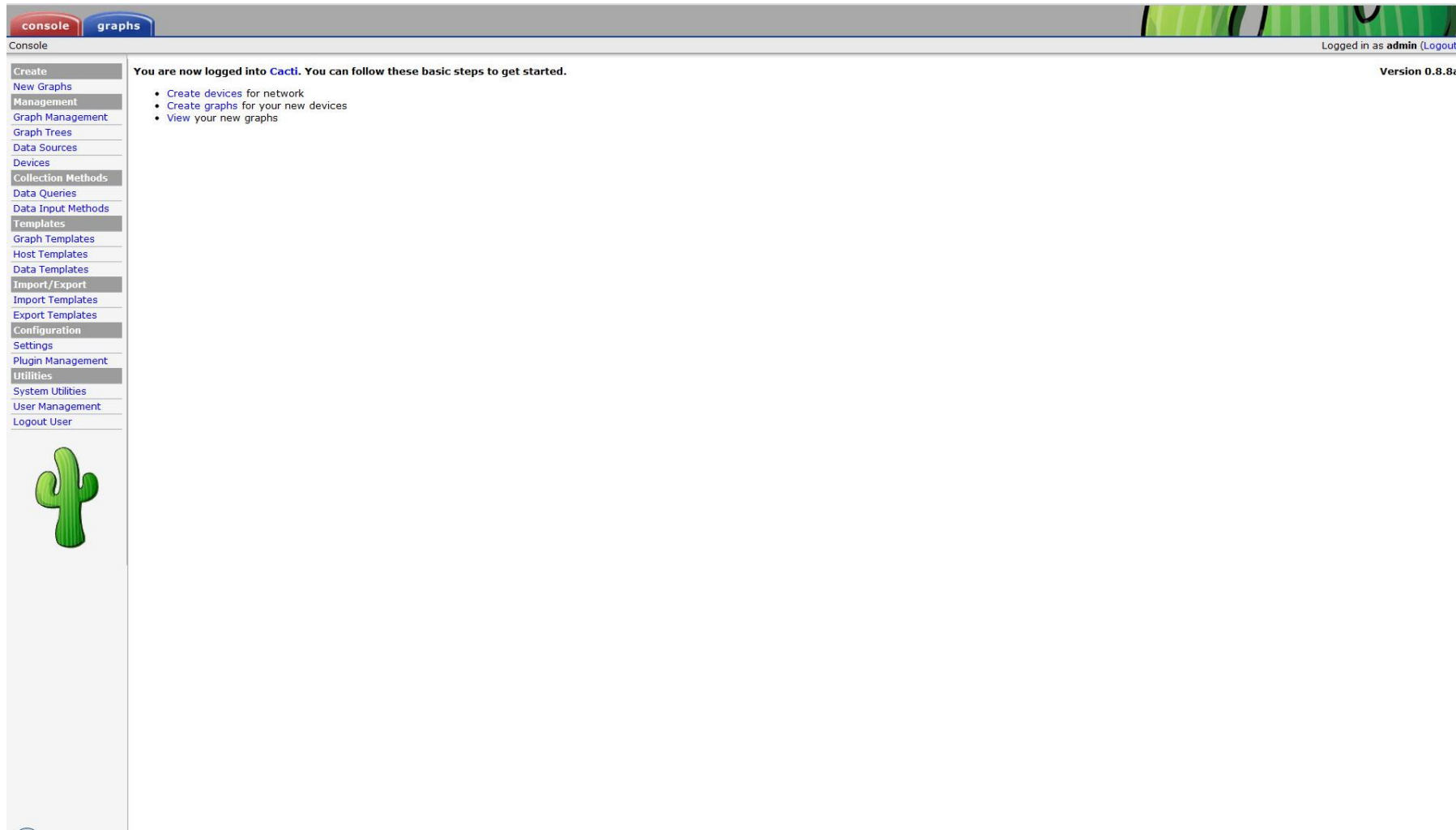

The screenshot displays the Cacti web interface. At the top, there are two tabs: "console" (selected) and "graphs". Below the tabs, the page is divided into a left sidebar and a main content area. The sidebar contains a navigation menu with the following items: Create, New Graphs, Management, Graph Management, Graph Trees, Data Sources, Devices, Collection Methods, Data Queries, Data Input Methods, Templates, Graph Templates, Host Templates, Data Templates, Import/Export, Import Templates, Export Templates, Configuration, Settings, Plugin Management, Utilities, System Utilities, User Management, and Logout User. Below the menu is a green cactus icon. The main content area features a welcome message: "You are now logged into Cacti. You can follow these basic steps to get started." followed by a bulleted list: "• Create devices for network", "• Create graphs for your new devices", and "• View your new graphs". In the top right corner, it says "Logged in as admin (Logout)" and "Version 0.8.8a".

# Cacti(7)

